



Pizza Oven
Model CE-CN-0016
Item 44308
Instruction Manual



Revised - 03/01/2023



Toll Free: 1-800-465-0234
Fax: 905-607-0234
Email: service@omcan.com
www.omcan.com



Table of Contents

Model CE-CN-0016

Section	Page
General Information -----	3 - 4
Safety and Warranty -----	4 - 6
Technical Specifications -----	6
Installation -----	6 - 7
Operation -----	7
Maintenance -----	7 - 8
Parts Breakdown -----	9 - 10
Electrical Schematics -----	10
Warranty Registration -----	11



General Information

Omcan Manufacturing and Distributing Company Inc., Food Machinery of America, Inc. dba Omcan and Omcan Inc. are not responsible for any harm or injury caused due to any person's improper or negligent use of this equipment. The product shall only be operated by someone over the age of 18, of sound mind, and not under the influence of any drugs or alcohol, who has been trained in the correct operation of this machine, and is wearing authorized, proper safety clothing. Any modification to the machine voids any warranty, and may cause harm to individuals using the machine or in the vicinity of the machine while in operation.

CHECK PACKAGE UPON ARRIVAL

Upon receipt of an Omcan shipment please inspect for external damage. If no damage is evident on the external packaging, open carton to ensure all ordered items are within the box, and there is no concealed damage to the machine. If the package has suffered rough handling, bumps or damage (visible or concealed), please note it on the bill of lading before accepting the delivery and contact Omcan within 24 hours, so we may initiate a claim with the carrier. A detailed report on the extent of the damage caused to the machine must be filled out within three days, from the delivery date shown in the shipping documents. Omcan has no recourse for damaged products that were shipped collect or third party.

Before operating any equipment, always read and familiarize yourself with all operation and safety instructions.

Omcan would like to thank you for purchasing this machine. It's of the utmost importance to save these instructions for future reference. Also save the original box and packaging for shipping the equipment if servicing or returning of the machine is required.

Omcan Fabrication et distribution Compagnie Limitée et Food Machinery d'Amérique, dba Omcan et Omcan Inc. ne sont pas responsables de tout dommage ou blessure causé du fait que toute personne ait utilisé cet équipement de façon irrégulière. Le produit ne doit être exploité que par quelqu'un de plus de 18 ans, sain d'esprit, et pas sous l'influence d'une drogue ou d'alcool, qui a été formé pour utiliser cette machine correctement, et est vêtu de vêtements de sécurité appropriés. Toute modification de la machine annule toute garantie, et peut causer un préjudice à des personnes utilisant la machine ou des personnes à proximité de la machine pendant son fonctionnement.

VÉRIFIEZ LE COLIS DÈS RÉCEPTION

Dès réception d'une expédition d'Omcan veuillez inspecter pour dommages externes. Si aucun dommage n'est visible sur l'emballage externe, ouvrez le carton afin de s'assurer que tous les éléments commandés sont dans la boîte, et il n'y a aucun dommage dissimulé à la machine. Si le colis n'a subi aucune mauvaises manipulations, de bosses ou de dommages (visible ou cachée), notez-le sur le bond de livraison avant d'accepter la livraison et contactez Omcan dans les 24 heures qui suivent, pour que nous puissions engager une réclamation auprès du transporteur. Un rapport détaillé sur l'étendue des dommages causés à la machine doit être rempli dans un délai de trois jours, à compter de la date de livraison indiquée dans les documents d'expédition. Omcan n'a aucun droit de recours pour les produits endommagés qui ont été expédiés ou cueilli par un tiers transporteur.

General Information

Avant d'utiliser n'importe quel équipement, toujours lire et vous familiariser avec toutes les opérations et les consignes de sécurité.

Omcan voudrais vous remercier d'avoir choisi cette machine. Il est primordial de conserver ces instructions pour une référence ultérieure. Également conservez la boîte originale et l'emballage pour l'expédition de l'équipement si l'entretien ou le retour de la machine est nécessaire.

Omcan Empresa De Fabricacion Y Distribucion Inc. Y Maquinaria De Alimentos De America, Inc. dba Omcan y Omcan Inc. no son responsables de ningun daño o perjuicio causado por cualquier persona inadecuada o el uso descuidado de este equipo. El producto solo podra ser operado por una persona mayor de 18 años, en su sano juicio y no bajo alguna influencia de droga o alcohol, y que este ha sido entrenado en el correcto funcionamiento de esta máquina, y ésta usando ropa apropiada y autorizada. Cualquier modificación a la máquina anula la garantía y puede causar daños a las personas usando la máquina mientras esta en el funcionamiento.

REVISE EL PAQUETE A SU LLEGADA

Tras la recepcion de un envio Omcan favor inspeccionar daños externos. Si no hay daños evidentes en el empaque exterior, Habra el carton para asegurarse que todos los articulos solicitados estén dentro de la caja y no encuentre daños ocultos en la máquina. Si el paquete ha sufrido un manejo de poco cuidado, golpes o daños (visible o oculto) por favor anote en la factura antes de aceptar la entrega y contacte Omcan dentro de las 24 horas, de modo que podamos iniciar una reclamación con la compañía. Un informe detallado sobre los daños causados a la máquina debe ser llenado en el plazo de tres días, desde la fecha de entrega que se muestra en los documentos de envío. Omcan no tiene ningun recurso por productos dañados que se enviaron a recoger por terceros.

Antes de utilizar cualquier equipo, siempre lea y familiarizarse con todas las instrucciones de funcionamiento y seguridad.

Omcan le gustaría darle las gracias por la compra de esta máquina. Es de la mayor importancia para salvar estas instrucciones para futuras consultas. Además, guarda la caja original y el embalaje para el envío del equipo si servicio técnico o devolución de la máquina que se requiere.

Safety and Warranty

IMPORTANT SAFETY INFORMATION

This manual contains important information regarding safe operation of your snack oven. Please read thoroughly before equipment setup, operation, or maintenance. Failure to comply with regular maintenance guidelines outlined in this manual may void the warranty!



Safety and Warranty

NOTE: SAVE THESE INSTRUCTIONS FOR FUTURE REFERENCE.

PRECAUTIONS FOR USAGE

- **DO NOT COME IN DIRECT CONTACT WITH HOT SURFACES.**
- Avoid cooking oversized foods.
- Keep the top of the unit clear. Do not store items on top of the unit.
- Do not stack ovens on top of each other.
- Do not cook greasy foods; grease may damage the heating coils.
- **ONLY PLUG INTO CORRECT GROUNDED OUTLET. FORCING THE UNIT INTO ANOTHER PLUG MAY CAUSE AN ELECTRICAL HAZARD.**
- **DO NOT PLUG IN, UNPLUG, OR OPERATE THE UNIT WITH WET HANDS AT RISK OF ELECTRICAL SHOCK.**
- Keep the unit, plug, and cord clear of liquid and do not immerse any part in liquid.
- When idle or cleaning, unplug the unit from outlet.
- Never leave the oven unattended during operation.
- This unit is not to be used for anything other than its intended use.
- Do not operate this oven outdoors.
- Keep unit and surrounding area clean and dry. Operate only on firm, level surfaces with 12" of clearance on the top and all sides.
- **DO NOT USE THE UNIT IF IT IS DAMAGED, IF THE CORD AND PLUG IS DAMAGED, OR IF THERE IS A MALFUNCTION AT ANY TIME.**
- Children and animals should be kept away from this unit.
- Only allow authorized professionals to conduct repairs. Incorrect installation, alterations, adjustments, and maintenance can lead to property loss and injury. Always consult a professional.
- Ensure the unit has a designated power supply of correct voltage and is adequate for continued usage.
- Opening or removing the cover of this unit will void the warranty.

RESIDENTIAL USERS: Vendor assumes no liability for parts or labor coverage for component failure or other damages resulting from installation in non-commercial or residential applications. The right is reserved to deny shipment for residential usage; if this occurs, you will be notified as soon as possible.

1 YEAR PARTS AND LABOUR BENCH WARRANTY

Within the warranty period, contact Omcan Inc. at 1-800-465-0234 to schedule a drop off to either an Omcan authorized service depot in the area, or to an Omcan Service warehouse to repair the equipment.

Unauthorized maintenance will void the warranty. Warranty covers electrical and part failures, not improper use.

Please see <https://omcan.com/disclaimer> for complete info.

Safety and Warranty

WARNING:

The packaging components are classified as normal solid urban waste and can therefore be disposed of without difficulty.

In any case, for suitable recycling, we suggest disposing of the products separately (differentiated waste) according to the current norms.

DO NOT DISCARD ANY PACKAGING MATERIALS IN THE ENVIRONMENT!

Technical Specifications

Model	CE-CN-0016
Temperature Range	65 - 299°C / 150 - 570°F
Timer	30 Minutes
Power	1700 W
Pizza Diameter	16" / 406mm
Electrical	110-120V / 60Hz / 1
Wire Rack Dimensions	17.1" x 18.3" / 435 x 465mm
Dimensions	24.7" x 21.7" x 10.3" / 628 x 552 x 262mm
Packaging Dimensions	27" x 23.6" x 11.4" / 690 x 600 x 290mm
Weight	24.6 lbs. / 11.2 kgs.
Item Number	44308

Installation

1. Ensure that there is at least 12 inches of clearance on all sides, including the top and back of the unit.
2. The oven should be installed on a flat, sturdy surface.
3. Be sure that the unit is properly grounded and only plugged into a grounded, 3-hole NEMA 5-20R outlet to minimize shock or fire hazard.
4. Line up the unit handle and panel together, being sure that the handle will flip upwards.
5. To insert the grill, insert the hook into the oval opening on the panel. The hook will be facing upwards when installing.
6. Place the washer on the bolt and insert into the top round hole through the handle and panel.
7. Secure tightly with the included screw from behind the panel.



Installation

PLEASE NOTE: Improper assembly of the flip up handle to the grill could cause the grill to turn or fall off when moving product, possibly causing injury or burns.

Operation

BEFORE USING YOUR OVEN

Using a small amount of detergent, wash the rack with soapy water. (NOTE: Do not use a spray or abrasive polishing agent.) Gently wipe down interior walls with a damp cloth. While washing this unit, do not touch the electric heating element. Do not soak the inside of the oven with water.

After cleaning as noted above, close the door and set timer for 5 minutes.

After the timer has reset to zero, open the oven door in order to remove any smoky residue from inside the oven. The heating elements are well lubricated and this initial use will help burn off the extra grease. A light amount of smoke is normal during this process.

USAGE INSTRUCTIONS

1. Plug in the unit. The oven requires no preheating.
2. Set the desired cook time by turning the knob of the timer switch.
IMPORTANT: MAINTAIN CONSTANT SUPERVISION OF THE OVEN WHILE IN USE!
3. Push the power switch on, the power indicator light is on. The oven start working.
4. Caution should be used when removing food from the oven. Oven mitts or other protective gear should be used to avoid skin contact with the hot panel.
5. Unplug the oven when not in use.

Maintenance

CLEANING INSTRUCTIONS

NOTE: To maintain cleanliness and increase life of the unit, the oven should be cleaned daily. Do not immerse the unit in water or any other liquid. If liquid enters the electrical components of the unit, it may cause a short circuit or electrical shock.

Use caution while cleaning as there may be sharp edges on or inside of the unit.

1. Allow unit to completely cool before cleaning.
2. Disconnect the cord from the outlet.

Maintenance

3. Slide out the crumb tray and remove any food debris or other soil.
4. Wipe the crumb tray with a damp cloth.
5. Return the crumb tray to its proper position.
6. Wipe the outside of the unit with a damp cloth, then wipe dry. To avoid damage, do not use abrasive cleaners or scouring pads. If soap or chemical cleaners are used, be sure they are completely rinsed away with clear water immediately after cleaning. Chemical residue could damage or corrode the surface of the unit.

Parts Breakdown

Model CE-CN-0016 44308

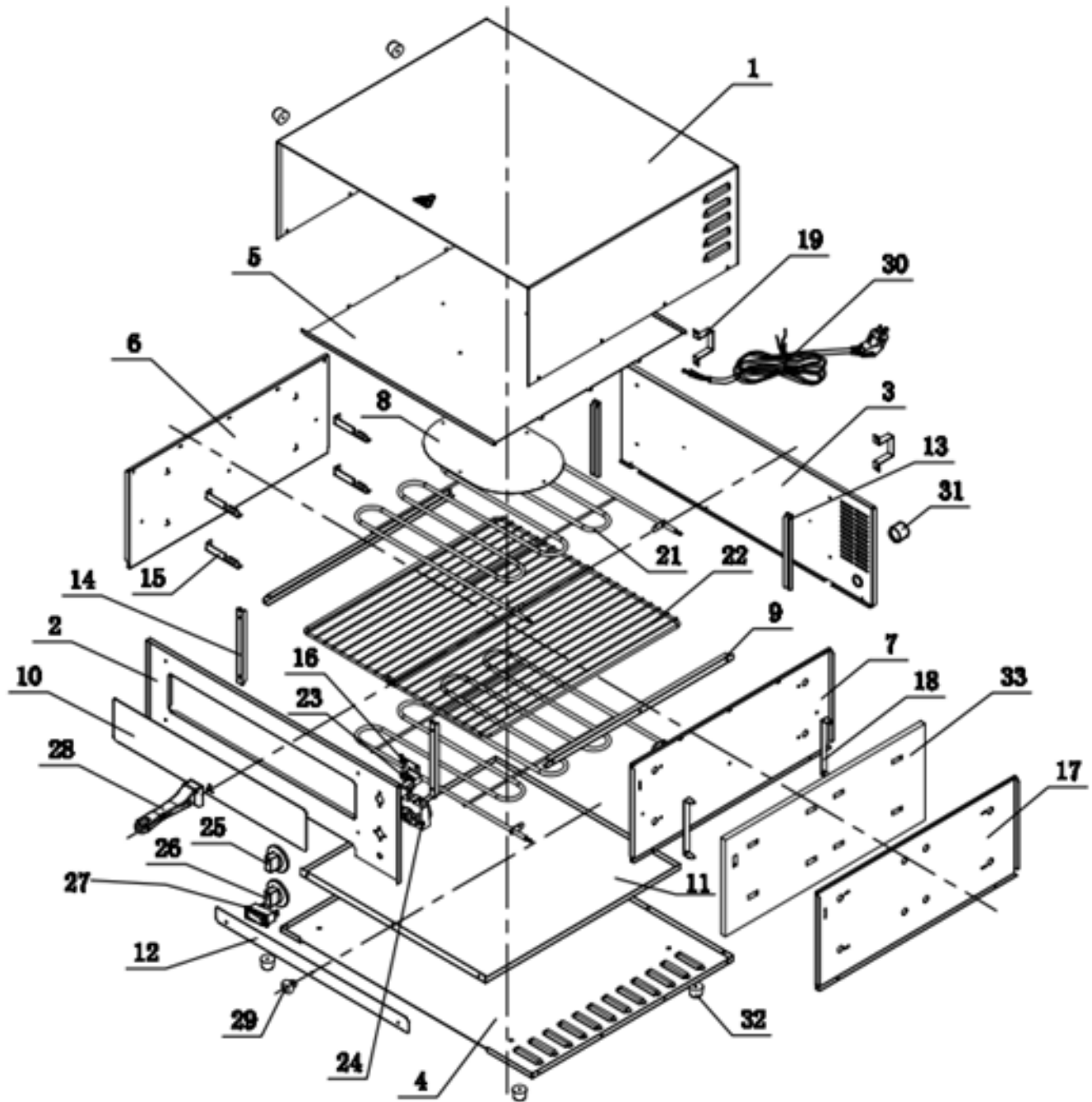

Parts Breakdown

Model CE-CN-0016 44308

Item No.	Description	Position	Item No.	Description	Position	Item No.	Description	Position
67501	Shell for 44308	1	67512	Crumb Tray Holding Plate for 44308	12	67523	Timer for 44308	24
67502	Front Panel for 44308	2	67513	Slot One for 44308	13	67524	Thermostat Knob for 44308	25
67503	Rear Board for 44308	3	67514	Slot Two for 44308	14	67525	Timer Knob for 44308	26
67504	Bottom Board for 44308	4	67515	Heating Element Supporter for 44308	15	67526	Power Switch for 44308	27
67505	Interior Ceiling Plate for 44308	5	67516	Conducting Strip for 44308	16	67527	Handle Assembly for 44308	28
67506	Interior Left Plate for 44308	6	67517	Separate Board for 44308	17	67528	Handle for 44308	29
67507	Interior Right Plate for 44308	7	67518	Separate Board Fixing Plate for 44308	18	67529	Power Cord for 44308	30
67508	Reflector Board for 44308	8	67519	Back Space Holder for 44308	19	67530	Buckle for 44308	31
67509	Food Tray Holder for 44308	9	67520	Heating Element for 44308	21	67531	Foot for 44308	32
67510	Tray Holding Plate for 44308	10	67521	Food Tray for 44308	22	67532	Insulation at Right Side for 44308	33
67511	Crumb Tray for 44308	11	67522	Thermostat for 44308	23			

Electrical Schematics

Model CE-CN-0016 44308

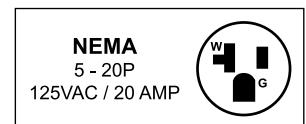
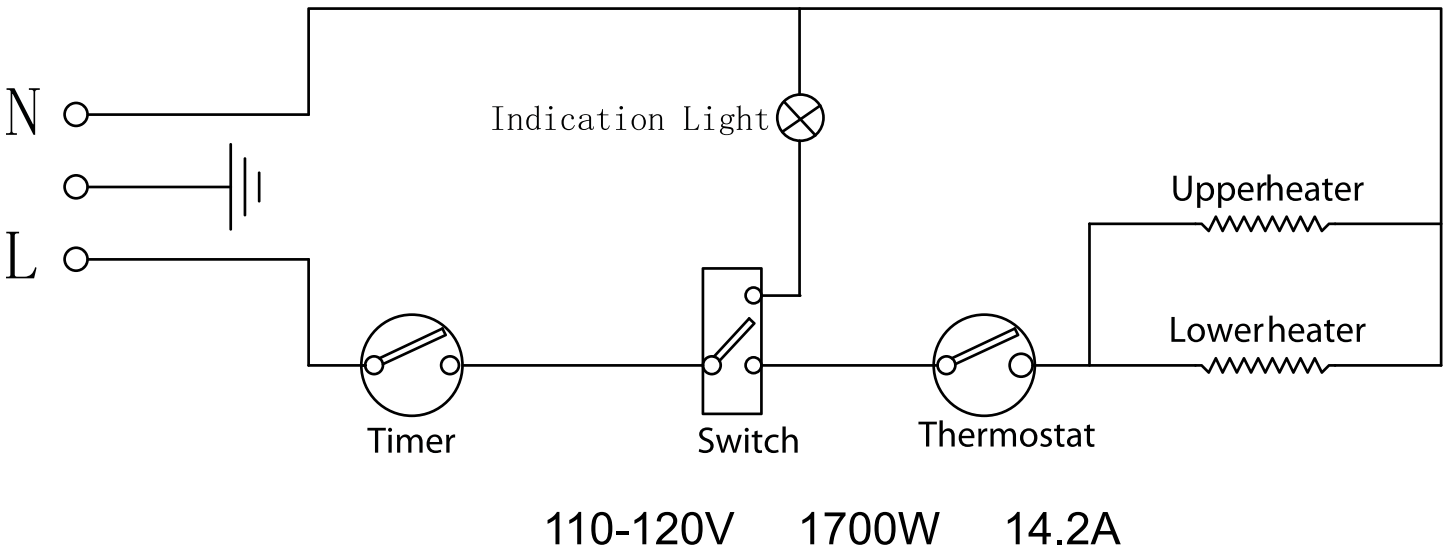



Warranty Registration

Thank you for purchasing an Omcan product. To register your warranty for this product, complete the information below, tear off the card at the perforation and then send to the address specified below. You can also register online by visiting:

Merci d'avoir acheté un produit Omcan. Pour enregistrer votre garantie pour ce produit, complétez les informations ci-dessous, détachez la carte au niveau de la perforation, puis l'envoyer à l'adresse spécifiée ci-dessous. Vous pouvez également vous inscrire en ligne en visitant:

Gracias por comprar un producto Omcan usted. Para registrar su garantía para este producto, complete la información a continuación, cortar la tarjeta en la perforación y luego enviarlo a la dirección indicada a continuación. También puede registrarse en línea en:

<https://omcan.com/warranty-registration/>

For mailing in Canada

Pour postale au Canada

Por correo en Canadá

OMCAN

PRODUCT WARRANTY REGISTRATION

3115 Pepper Mill Court,

Mississauga, Ontario

Canada, L5L 4X5

For mailing in the US

Pour diffusion aux États-Unis

Por correo en los EE.UU.

OMCAN

PRODUCT WARRANTY REGISTRATION

4450 Witmer Industrial Estates, Unit 4,

Niagara Falls, New York

USA, 14305

or email to: service@omcan.com



Purchaser's Information

Name: _____

Address: _____

City: _____ Province or State: _____ Postal or Zip: _____

Country: _____

Dealer from which Purchased: _____

Dealer City: _____ Dealer Province or State: _____

Invoice: _____

Model Name: _____ Model Number: _____

Machine Description: _____

Date of Purchase (MM/DD/YYYY): _____

Would you like to extend the warranty? Yes No

Company Name: _____

Telephone: _____

Email Address: _____

Type of Company:

Restaurant Bakery Deli

Butcher Supermarket Caterer

Institution (*specify*): _____

Other (*specify*): _____

Serial Number: _____

Date of Installation (MM/DD/YYYY): _____

Thank you for choosing Omcan | Merci d'avoir choisi Omcan | Gracias por elegir Omcan



Since 1951 Omcan has grown to become a leading distributor of equipment and supplies to the North American food service industry. Our success over these many years can be attributed to our commitment to strengthen and develop new and existing relationships with our valued customers and manufacturers. Today with partners in North America, Europe, Asia and South America, we continually work to improve and grow the company. We strive to offer customers exceptional value through our qualified local sales and service representatives who provide convenient access to over 6,500 globally sourced products.

Depuis 1951 Omcan a grandi pour devenir un des “leaders” de la distribution des équipements et matériel pour l’industrie des services alimentaires en Amérique du Nord. Notre succès au cours de ces nombreuses années peut être attribué à notre engagement à renforcer et à développer de nouvelles et existantes relations avec nos clients et les fabricants de valeur. Aujourd’hui avec des partenaires en Amérique du Nord, Europe, Asie et Amérique du Sud, nous travaillons continuellement à améliorer et développer l’entreprise. Nous nous efforçons d’offrir à nos clients une valeur exceptionnelle grâce à nos ventes locales qualifiées et des représentants de service qui offrent un accès facile à plus de 6500 produits provenant du monde entier.

Desde 1951 Omcan ha crecido hasta convertirse en un líder en la distribución de equipos y suministros de alimentos en América del Norte industria de servicios. Nuestro éxito en estos años se puede atribuir a nuestro compromiso de fortalecer y desarrollar nuevas relaciones existentes con nuestros valiosos clientes y fabricantes. Hoy con socios de América del Norte, Europa, Asia y América del Sur, que trabajan continuamente para mejorar y crecer la empresa. Nos esforzamos por ofrecer a nuestros clientes valor excepcional a través de nuestro local de ventas y representantes de los servicios que proporcionan un fácil acceso a más de 6,500 productos con origen a nivel mundial.

